

REMOTE ELECTROTORQUE WRENCHES

OPERATORS HANDBOOK (PART NO. 34132)

This tool has been tested to the following EEC directives and standards:

EMC Directive 89/336/EEC and amendment 91/263/EEC & 92/31/EEC.
Standards EN55014:1987, IEC 801-2, IEC 801-4, IEC 801-3.

Low Voltage Directive 73/23/EEC:1995.
Standard BS2769 part 1 for a class 1 tool, where applicable.

This tool must be operated as a composite item with its transformer controller. The tool operates at SE LV 42 V DC. The tool is double insulated, but with an earthed screen for EMC reasons.

Machineries Directive 89/392/EEC amended 91/368/EEC:1992, amendment 93/44/EEC:1993.
Standards BS EN 292 parts 1 and 2, where applicable.

CE Marking Directive 93/68/EEC:1995

This statement covers all electrical power tools from Norbar with the prefix 'E'.

A copy of the Manufacturer's Declaration of Conformity may be obtained if required, from Norbar Torque Tools, Banbury, Oxfordshire, OX16 7XJ.

Sound Level at Operator's Position: approx. 63 dB

Vibration Level at Wrench: Does not exceed 2.5 m/s²

WARNING: DO NOT OPERATE THIS TOOL BEFORE READING THESE INSTRUCTIONS.

Remote Electrotorque wrenches are reversible, non impacting, torque controlled bolt tightening tools and must always be operated with the following:-

- Norbar Transformer/Controller (mains supply isolated with an output of 42 VDC).
- Impact Quality Sockets.
- Reaction Arm.
- Remote Box(es).

Where the intended usage is not with threaded fasteners, the safety of operation must be evaluated and appropriate precautions taken. Your distributor will be pleased to advise you.

These tools have not been designed to work in certain positions in wet conditions.

These tools contain grease, which may cause an explosion hazard in the presence of pure oxygen. These tools contain aluminium alloy components which may cause a hazard in certain explosive environments. Please contact your distributor for details of solutions to these hazards.

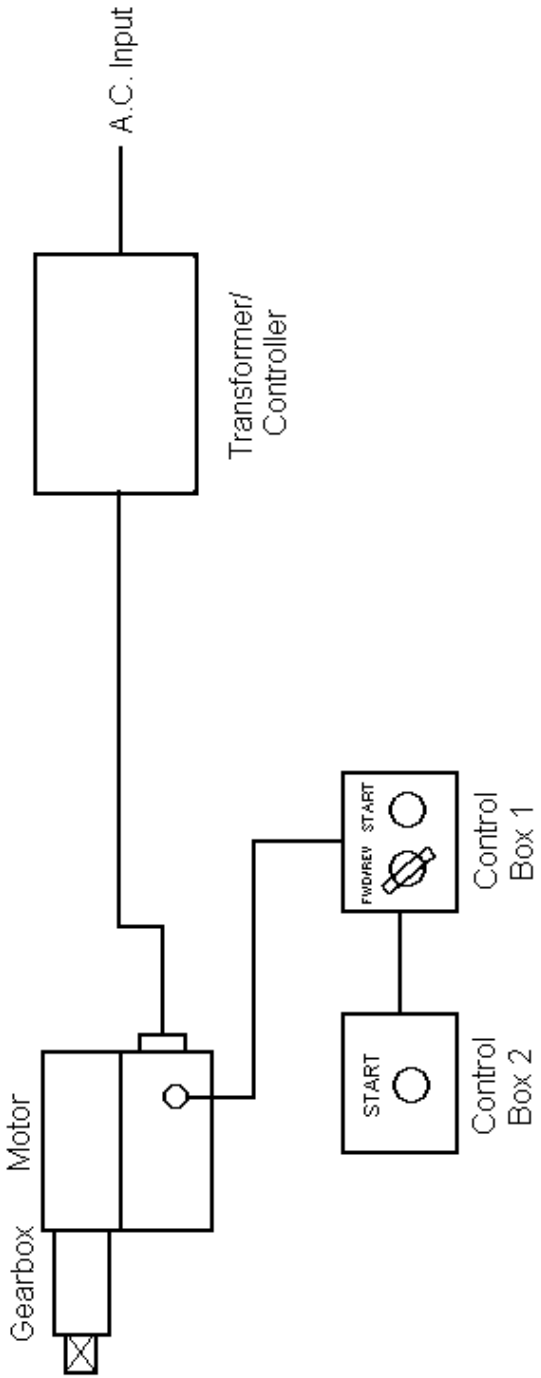

FIG 3
Block Diagram of Remote Tool Control System

ASSEMBLY

1. Fit the control box(es) to the required position. (as shown on block diagram, Figure 3). Connect to the tool.
2. Ensure tool is plugged into the Norbar Electrotorque Transformer/Controller.
3. Slide cover over the Tool's electrical connector and lock into place with Allen Key.

Note: *Do not connect Transformer/Controller to mains before locking cover.*

4. Plug Transformer/Controller into the voltage supply as stated on the Transformer Rating Label.
5. Switch on, select direction of rotation required and depress Trigger (H) to check Direction of Rotation. Release trigger.
6. a) For ET500 - ET2000. Attach the Reaction Arm (B) to Reaction Plate (C) adjacent to the Output Drive (D) of wrench ensuring the Locking Plunger is correctly engaged in the Reaction Arm. Or for double reaction plate, slide on plate and fit circlip.
b) For ET1 to ET14. Attach reaction plate (N) using bolts provided. The bolts holding the reaction plate to the gearbox (M) have a torque setting which is stamped onto the plate. The torque should be checked periodically.
c) For ET2700 and ET5500. Remove the circlip from the spline, slide on the reaction plate, replace the circlip.

SETTING THE TOOL

The Electrotorque is factory set for controlled torque tightening in the clockwise direction and full torque output in the anti-clockwise direction. This mode of operation can be reversed for left hand threaded bolts or torque control applied in both directions.

SETTING TORQUE FOR BOLT TIGHTENING _____

1. Select 'set torque'.
2. Set torque required on the digital display by the 'Torque Set Control'.
3. Select torque monitor if required.

Note: *The monitor position is an inexact reading of final torque achieved.*

The Tool is now ready for use.

SETTING TORQUE FOR BOLT LOOSENING _____

1. Set the direction of operation.

The Tool is now ready for use.

OPERATING THE WRENCH

1. Fit the wrench with the correct size impact quality socket to suit the bolt to be tightened.
2. Check Clock/Anti-clock Switch on the control box is set correctly.
3. Rotate tool into convenient position relative to Reaction Arm (B.).
4. Fit the tool onto the bolt to be tightened with the Reaction Arm (B.) adjacent to the reaction point.
5. Briefly operate start button(s) to bring the Reaction Arm into contact with the reaction point.

WARNING: KEEP HANDS CLEAR OF REACTION ARM.

WARNING: IN USE, THIS TOOL MUST BE SUPPORTED AT ALL TIMES IN ORDER TO PREVENT UNEXPECTED RELEASE IN THE EVENT OF FASTENER OR COMPONENT FAILURE. (A BALANCER IS AVAILABLE FOR HANGING THE TOOL.)

6. Depress start button(s) and keep depressed until wrench stops. If the button(s) is released before the wrench stops, full torque will be applied to the bolt.
7. Release start button(s) and remove tool from bolt.

TORQUE OUTPUT ACCURACY

Explanation of Joint Rate (Hard or Soft)

Electrotorque output accuracy, as with all types of powered bolt tightening tools, is dependent on the Joint Rate of the fastener. (The Joint Rate being the relationship between bolt rotation and increase in applied torque).

There are three basic joint types defined in International Standards. (See figure 4).

An example of a typical Hard Joint would be a comparatively short bolt tightened directly into a solid component with metal to metal contact between the mating surfaces. A Soft Joint would have comparatively long bolts, with a flexible sealing gasket between the mating surfaces. A Normal Joint is between these two conditions.

Annular torque transducers and associated instrumentation, giving an accuracy of better than +/-1% F.S.D., are available as optional extras.

Contact your local distributor for details.

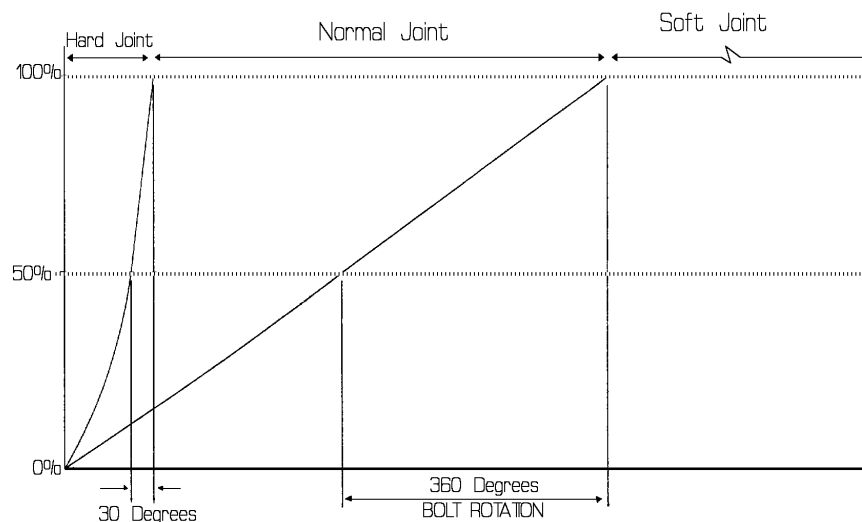

FIG 4

SERVICING

Electrotorque tools need, on a regular basis to be inspected for wear of the electrical cables and have them replaced if required with Norbar Approved cables. Connectors should also be inspected for undue wear and replaced if required.

Annually the Motor brushes should be inspected and replaced if well worn.

Technical assistance, spare parts, repair and recalibration services are all available through your authorised Norbar Distributor.

LUBRICATION

Wrench Gearbox:-

BP Energrease LS-EP1 or equivalent good quality grease.

FAULT FINDING

<u>FAULT</u>	<u>REMEDY</u>
Motor will not start.	Check all power is connected. Check all connectors are tight. Ensure start button(s) is being fully depressed. Remove power to transformer/controller can check the 2x2A fuses on the motor controller board, located on main printed circuit load under lid on transformer/controller. Check brushes on motor.
Motor running in wrong direction.	Check direction switch.
Motor shuts off before torque is reached	Check torque setting of Electrotorque is high enough.

Refer to Service Manuals for further details.

Manufacturer's Name and Address:

Norbar Torque Tools Ltd
Beaumont Road
Banbury
Oxfordshire
OX16 7XJ
United Kingdom
Tel: + 44 (0) 1295 270333
Fax: + 44 (0) 1295 753643

For Service Contact :

